

## D375Q7JD, D375QH7JD



- Exclusive Three Year Warranty
- Automatic 0 to 100% Capacity Control
- Two Stage Dry Type Air Filter
- One 1 1/2" and One 3/4" Service Valves
- Oil Level Sight Gauge
- John Deere 4045T
- Steel Fuel Tank
- Cooler Access Panel for Cleaning
- Safety Chains
- 15" Wheels with Steel Belted Radial Tires
- Choice of Adjustable Height Lunette Eye or Ball Hitch on Drawbar
- Large Full Length Lockable Tool Boxes on Each Side
- Noise Level Limited to Maximum of 76 dBA at 7 Meters
- Easily Removable Canopy
- Automatic Shutdown and Protection System
- Automatic Blowdown Valve
- Stop, Turn, Tail Lights
- Unloaded Starting
- Standard Instrumentation
  - Alternator Light*
  - Fuel Level Gauge*
  - Discharge Pressure Gauge*
  - Hourmeter*
  - Engine Oil Pressure Gauge*
  - Engine Water Temperature Gauge*
- Optional Equipment
  - 3rd Wheel*
  - Hydraulic Surge Brakes*
  - Drawbars*
  - Hitches*
  - Hose Reels*
  - Gauges*
  - Tachometer*
  - Ether Starting*
  - PLUS MANY OTHERS*



**DIMENSIONS**

(Metrics in Parentheses)

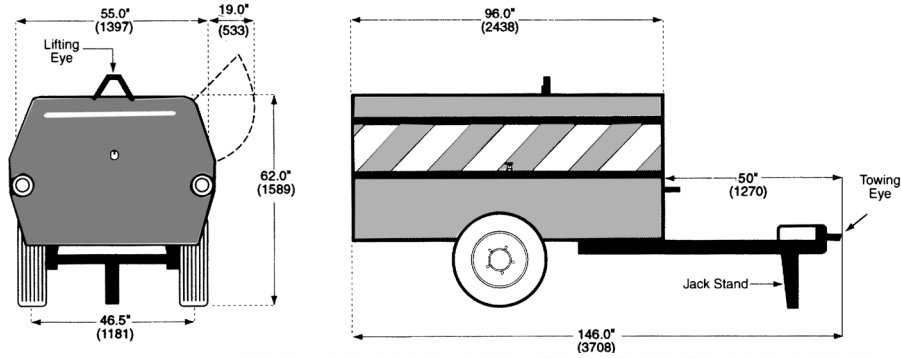

**SPECIFICATIONS**

(Metrics in Parentheses)

**COMPRESSOR**

**D375Q7JD**

**D375QH7JD**

*Type*

Ambient Oper. Temp. Range

Oil Capacity

Total Receiver Volume

Air Service Connections

Type Cooling System

Type Air Intake System

Type of Control

Tire Size

Rated Delivery

Rated Operating Pressure

Operating Pressure Range

Weight, Serviced

*Single stage, oil flooded rotary screw*

-20° to +125°F (-29° to +52°C)

10 gal. (38 L)

3.6 ft.<sup>3</sup> (102L)

One 1 1/2" NPT / 1 3/4" NPT

Oil to Air

Two Stage Dry

0-100% Demand

P225/75D15 Load Range C

375 cfm (10.6 m<sup>3</sup>/min)

100 psig (700 kPa)

70-125 psig (480-860 kPa)

3400 lbs.

*Single stage, oil flooded rotary screw*

-20° to +125°F (-29° to +52°C)

10 gal. (38 L)

3.6 ft.<sup>3</sup> (102L)

One 1 1/2" NPT / 2 3/4" NPT

Oil to Air

Two Stage Dry

0-100% Demand

P225/75D15 Load Range C

375 cfm (10.6 m<sup>3</sup>/min)

150 psig (1050 kPa)

70-170 psig (480-1170 kPa)

3400 lbs.

**ENGINE**

**D375Q7JD**

**D375QH7JD**

*Type*

Make

Model

Number of Cylinders

Bore and Stroke

Displacement

Total Oil Capacity

Cooling System Capacity

Battery Rating

CCA @ 0° F

Idle Speed

Fuel Tank Capacity

Horsepower @ rated RPM

Full Load Speed

*Diesel*

John Deere

4045T

4

4.19" x 5.00" (106 x 127 mm)

276 in<sup>3</sup> (4.5L)

14 qts. (13.25 L)

16 qts. (15.1 L)

12 Volts

900 Amps

1400 RPM

40 gal. (195 L)

115 (86kw)

2500 RPM

*Diesel*

John Deere

4045T

4

4.19" x 5.00" (106 x 127 mm)

276 in<sup>3</sup> (4.5L)

14 qts. (13.25 L)

16 qts. (15.1 L)

12 Volts

900 Amps

1400 RPM

40 gal. (195 L)

125 (93kw)

2500 RPM